

## SPECIFICATIONS (See notes 1 - 3)

- Horn Type:** Pattern Control, High frequency horn  
**Operating Range:** 800 Hz - 20 kHz  
**Usable LF Limit:** 550 Hz  
**Flare Rate:** 490 Hz  
**Throat Diameter:** 2 in. / 51 mm  
**Axial Sensitivity 1W/1m (with TAD4001 driver):**  
 115 dB SPL (1 kHz - 16 kHz 1/3 octave bands)  
**Maximum Output (with TAD4001 driver):**  
 130 dB SPL / 133 dB SPL peak  
**Nominal -6 dB Beamwidth:**  
 Horizontal: 60° (+18° / -8°, 1 kHz - 16 kHz)  
 Vertical: 35° (+17° / -6°, 2 kHz - 16 kHz)  
**Axial Q:** 21.3 (1 kHz - 16 kHz)  
**Axial DI:** 13.3 (1 kHz - 16 kHz)  
**Recommended Signal Processing (for 2 in / 51 mm driver):**  
 1 kHz or higher crossover point

### Construction:

Hand-laminated, reinforced composite, black fiberglass  
 Double wall construction using embedded balsa wood

### Required Accessories:

Electronic crossover, Equalization

### Optional Accessories:

DSC42: Digital crossover / processor  
 2BKT: Rear yoke-type bracket  
 M200RC: Weather-resistant driver cover  
 M4COAXBKT: For mounting PC442 to a  
 PC1500 series horn

### Bolt Patterns:

- (8) 5/16 in. / 8 mm holes on 7 in. / 178 mm bolt circle
- (4) 5/16 in. / 8 mm holes on 4 in. / 102 mm bolt circle

### Dimensions:

Height: 11.5 in. / 292 mm  
 Width: 14.25 in. / 362 mm  
 Depth: 9.75 in. / 248 mm

**Weight:** 4 lb. / 1.8 kg

**Shipping Weight:** 6 lb. / 2.7 kg

**1. Sensitivity:** Free field pink noise measurement at 15 ft / 4.6 m at 5% power; extrapolated to 1 meter and an input of 2.83 volts RMS. 0 dB SPL = 20 uPa.

**2. Watts:** All wattage figures are calculated using the rated nominal impedance.

**3. EQ:** Specifications are without equalization, normally required for optimum performance.

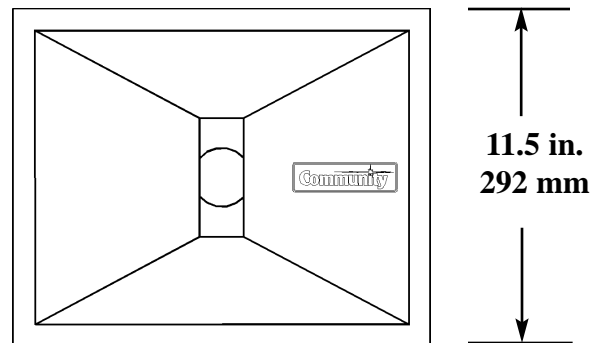

## APPLICATIONS:

- Voice Announcement
- Sports Facilities
- Performing Arts
- Concert Systems
- Houses of Worship

## FEATURES:

- Precise Horizontal and Vertical Control Maintains Consistent On and Off Axis Frequency Response
- High Q Design Provides Increased Intelligibility Over Distance
- Strong, Light Weight, Non-Resonant, Weather Resistant Fiberglass Construction

## DESCRIPTION

The PC464 horn is designed by Community to function as a high frequency horn in a multi-way component system. Mated with a high quality 2" compression driver it will provide focused, extremely high output sound projection, with predictable performance and exceptional long term durability for professional sound reinforcement systems. Performance data for Community horns is well documented, providing the designer and consultant with highly predictable and consistent coverage patterns for system design.

Each horn is a handcrafted, one-piece, precision waveguide, precision molded in hand-laminated, fiber-reinforced fiberglass. Balsa wood is embedded in the sidewalls for non-diaphragmatic, resonant-free operation. With substantial fiberglass layering and integral throat and driver flange construction, Community horns are built to withstand the torque loads of the heaviest compression drivers. Their inherent strength and rigidity enhances sonic efficiency by preventing sound energy losses through the horn walls or from vibration. Community fiberglass horns are inherently weather-proof under all conditions of use. There is a five year warranty.

**FREQUENCY RESPONSE (with TAD4001)**

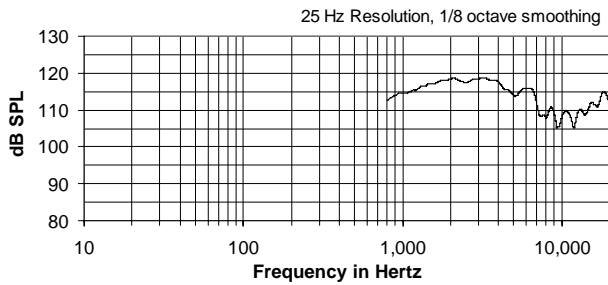

**IMPEDANCE (with TAD4001)**

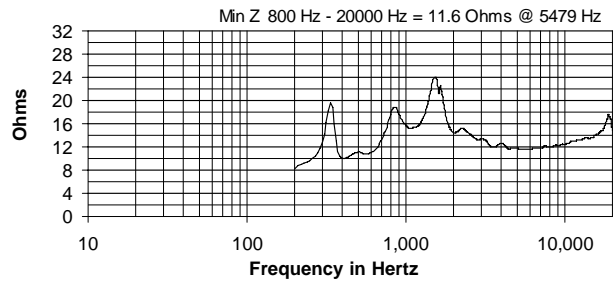

**BEAMWIDTH**

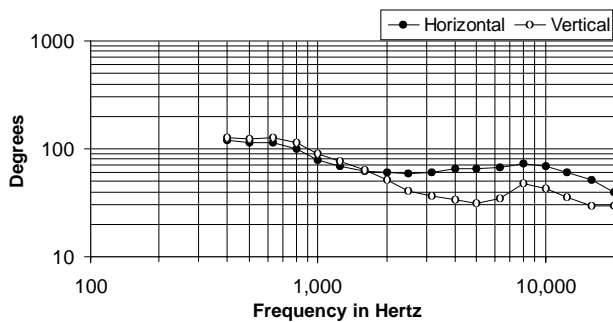

**AXIAL Q**

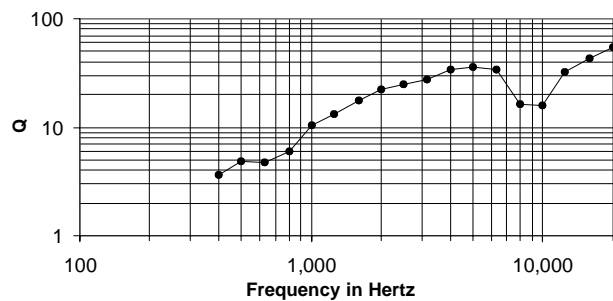

**DIMENSIONS**

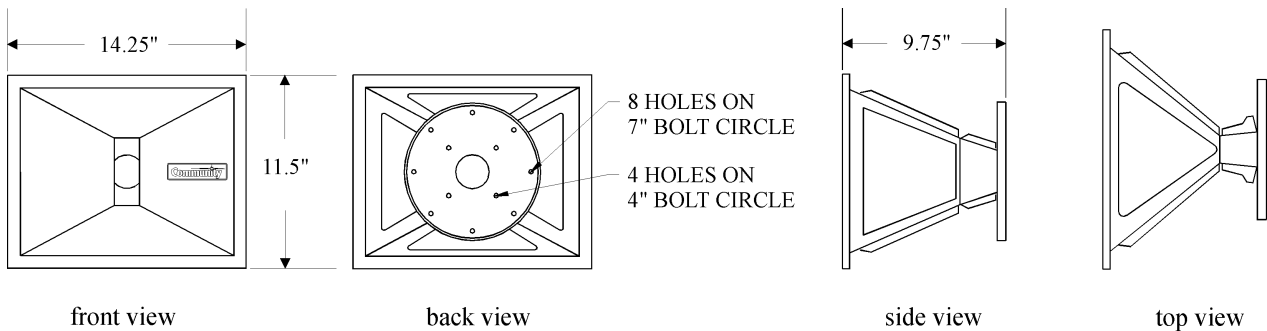

**ARCHITECTS' AND ENGINEERS' SPECIFICATIONS**

The horn shall be a 2 inch throat entrance, Pattern Control, high frequency device. It shall be made as one piece using hand-laminated fiberglass, with double wall constructions formed by resin-encapsulated, sandwich core wood. It shall include an integral rear flange for mounting a 2 inch exit compression driver and a flat, front flange to facilitate mounting. The usable operating range shall be from 800 Hz to 20 kHz with nominal -6 dB beamwidths of 60° horizontal, deviating no more than +18° / -8° between 1 kHz and 16 kHz, and 35° vertical, deviating no more than +17° / -6° between 2 kHz and 16 kHz. The horn shall be 11.5 in. (292 mm) H x 14.25 in. (362 mm) W x 9.75 in. (248 mm) D, and weigh 4 lb. (1.8 kg).